

Now there's a better way to handle ash, from top to bottom.

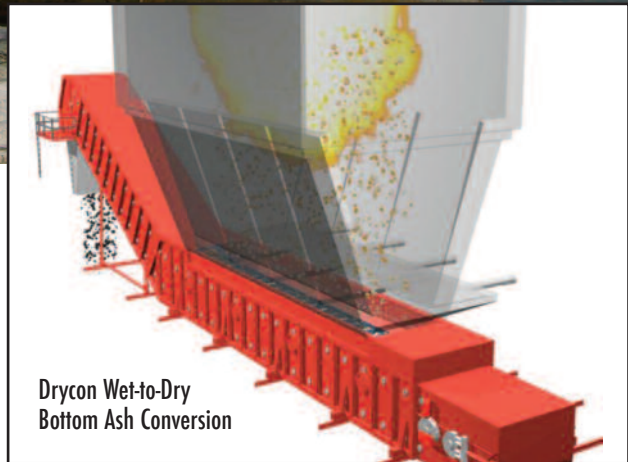

We're bringing new technology and new thinking to the issue of ash handling and ash ponds. Through wet-to-dry fly ash conversion, dry bottom ash handling, and sorbent injection technology, we eliminate the need for ash ponds.

Our turnkey system offers design, supply, construction, installation and project management, all from a single, cost-saving source. It's a winning combination that will lower your operating costs and provide significant environmental benefits.



Drycon Wet-to-Dry
Bottom Ash Conversion

We're Roberts & Schaefer and Clyde Bergemann Delta Ducon. Take advantage of our smart new solutions to your ash handling problems.

***We can do the whole job,
from top
to bottom.***

Call 312-846-5910 or 610-695-9700.



Roberts & Schaefer Company



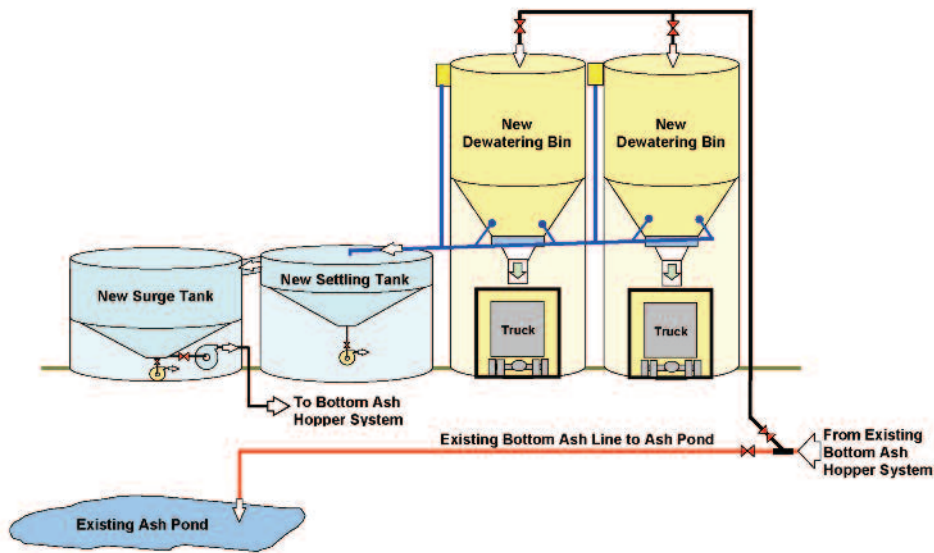
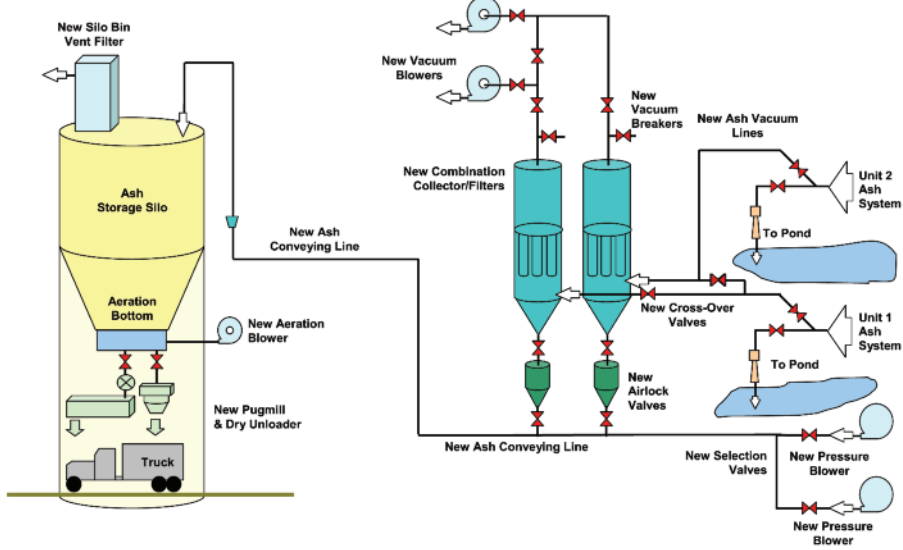

Submerged Scraper Conveyor (SSC)
 Drycon Continuous Dry Bottom Ash Handling
 Wet to Dry Pneumatic Fly Ash Conversion
 Wet-Ash Recirculization System



Roberts & Schaefer Company

